

LOVOL

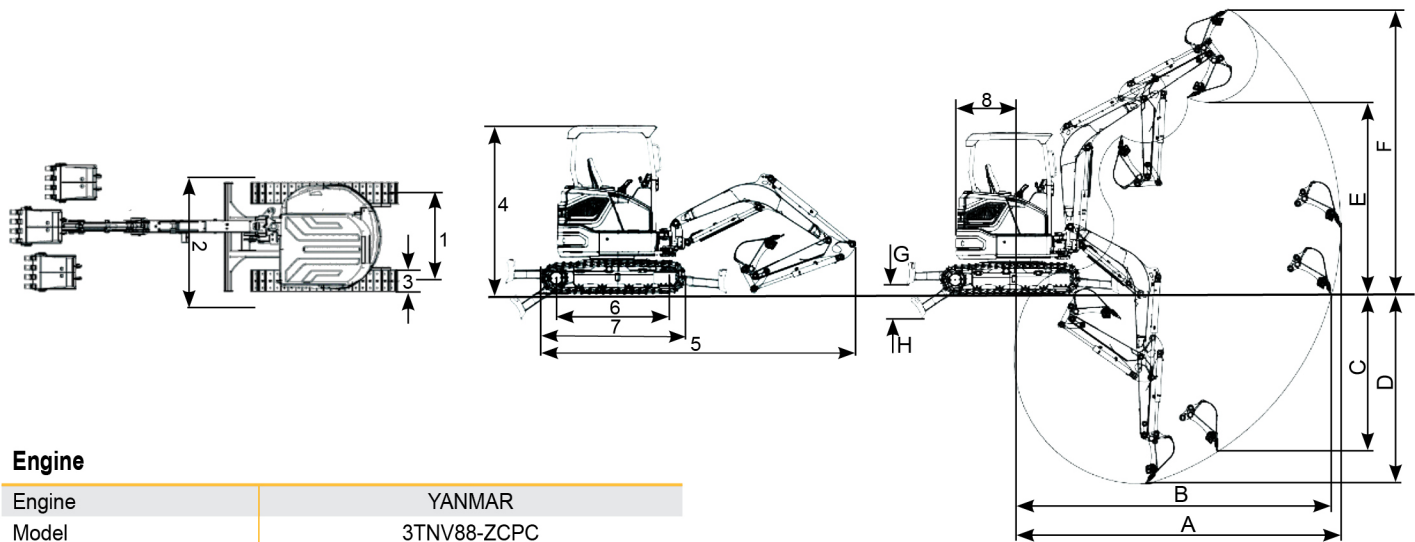

Engine	YANMAR
Rated Power	22.2kW
Bucket Capacity	0.12 m ³
Operation Weight	3800kg

Model
FR36F-U
HYDRAULIC EXCAVATOR



Engine

Engine	YANMAR	
Model	3TNV88-ZCPC	
Engine Type	Diesel Engine, 4 Stroke, Water Cooled, Direct Injection	
Number of Cylinder	3	
Engine Power / Speed	22.2kW / 2400rpm	
Engine Torque / Speed	103N·m / 1600rpm	
Displacement	1.642L	
Fuel Tank Capacity	40L	42L

- In heavy duty working applications, the main computer controller automatically adjusts power and speed according to the change of the load to ensure high output power, so as to the efficiency will be improved significantly

Walking drive

Type	Hydraulic	
Travel Speed (Max. / Min)	4.2km/h / 2.7km/h	4.4km/h / 2.72km/h
Max. Traction Force	35.1kN	35kN
Gradeability	30°	
Track Number (Each side)	43	
Upper Roller / Lower Roller (Each side)	1 / 4	
Ground Pressure	34.7kPa	
Track Type	Double grouser	
Track Gauge (1)	1400mm	
Shipping Width (2)	1700mm	
Track Width (3)	300mm	
Wheel Tread (6)	1620mm	
Track Length (7)	2080mm	

- The track can be adjustable of tension.
- The left and right track driving independently.

Hydraulic System

Hydraulic Pump	Variable flow axial piston pump
Hydraulic Flow	108L/min
Hydraulic Pressure	24.2MPa
Hydraulic oil tank	20L

- Hydraulic safety lock
- The system will automatically detect the pressure when face big frustration during digging, and automatically adjusts output pressure to keep the powerful force in digging process

Electrical System

Electric system	12V
Battery	12V 55Ah × 1 units

Working Performance

Cab Height (4)	2470mm			
Overall Length (5)	4650mm			
Tail Turning Radius (8)	850mm			
Bucket Type	Standard Bucket With Teeth And Side Cutter			
Bucket Capacity (SAE Heaped)	0.12m³			
Bucket Width	520mm			
Bucket Digging Force	30kN			
Arm Digging Force	19kN			
360° Swing Speed	8.4/min	9r/min		
Blade Dozer	1700mm × 340 mm	1700mm × 400 mm		
Blade Dozer Lifting Height (G)	395mm			
Blade Dozer Falling Height (H)	425mm			
Arm Type	5.2m	5.25m	5.46m	5.62m
Max. Digging Radius (A)	5200mm	5250mm	5460mm	5620mm
Max. Digging Radius On Ground Level (B)	5150mm	5240mm	5400mm	5520mm
Max. Vertical Digging Depth (C)	2600mm	2725mm	2850mm	2950mm
Max. Digging Depth (D)	2850mm	3100mm	3200mm	3310mm
Max. Unloading Height (E)	3425mm	3500mm	3550mm	3780mm
Max. Digging Height (F)	4840mm	4900mm	5100mm	5180mm

Cab

- All weather steel cap with safety glass, ROPS/FOPS cab, safe work, air condition
- Adjustable seat with safety belt is very comfortable
- Wipers, radio
- LCD Display screen: hour meter, voltage charger, water-cooling temperature, engine oil pressure, hydraulic oil pressure, fuel level, etc., and add trouble code diagnostic and maintenance monitor functions which are convenient for operator to find the failure and do the routine maintenance on time

Optional Configuration

<input type="checkbox"/> Hydraulic breaker	<input type="checkbox"/> Hydraulic auger
<input type="checkbox"/> Quick coupler	<input type="checkbox"/> Flail Head
<input type="checkbox"/> Rubber track pad	<input type="checkbox"/> GPS system on computer, smartphone (android, IOS)